

## SENSOR DATA SHEET

## EPG Interface Sensor 4-Wire With Bracket

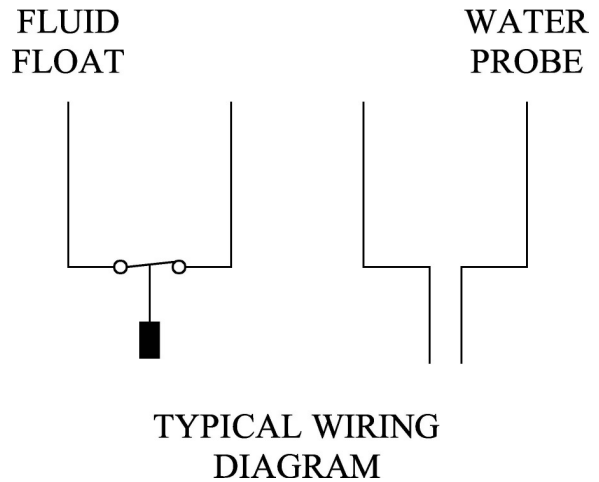
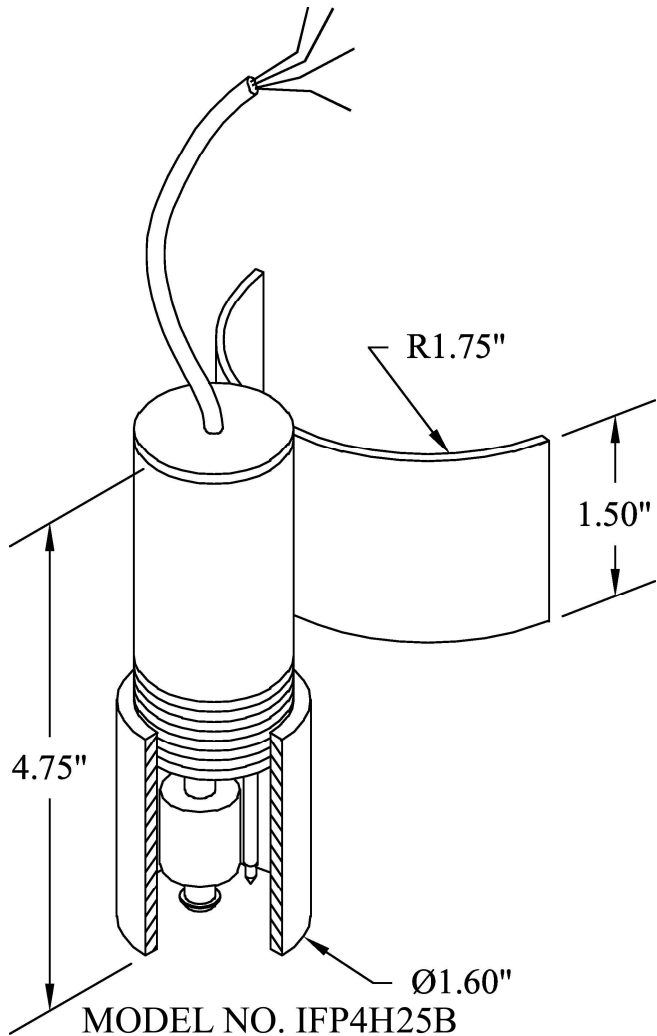

### SENSOR LOGIC AND FUNCTION

EPG's 4-wire interface sensor is a small diameter, product/water or air sensor with a bracket that mounts directly to a 4" submersible product (petroleum) recovery pump. It incorporates a normally closed (N.C.) level displacement sensor (float) with normally open (N.O.) conductivity probes. The level displacement sensor floats in either water or product. Built in conjunction with the level displacement sensor are conductivity probes. This combination allows the interface sensor to detect whether it is positioned in product, water, or air. The standard lead length is 25' and has

a waterproof, gasoline, oil, and chemical resistant outer jacket over four color-coded insulated signal wires. The housing is stainless steel with a removable PVC sleeve. It can be used as either an indicator, or as a product pump sensor. In the latter application, the level displacement sensor enables or disables a submersible product recovery pump, and the conductivity probes start the pump in free phase petroleum hydrocarbons. The sensor prevents the product pump from pumping water or running dry. A start time delay circuitry is recommended for product pump control. Typically, the interface sensor sends signals to intrinsically safe (IS) relays, which signal the detection of product/water/air, and start and stop a pump. These control circuits have an energy potential so low that they are incapable of causing ignition of flammable or combustible materials. Maximum load of sensor is one (1) Amp and maximum voltage is 240VAC.